

# 2.1 REGLEMENTARI URBANISTICE - ZONIFICARE

## PLAN INCADRARE IN ZONA

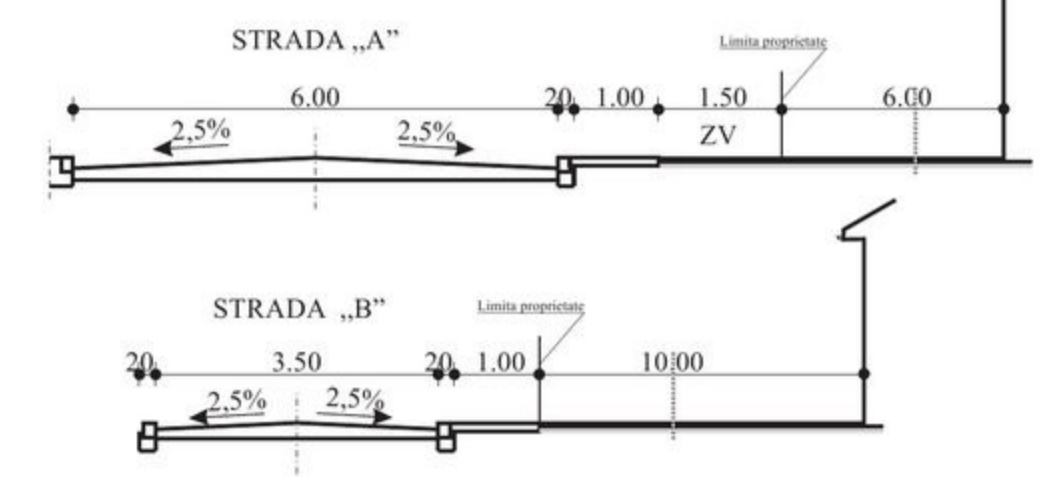
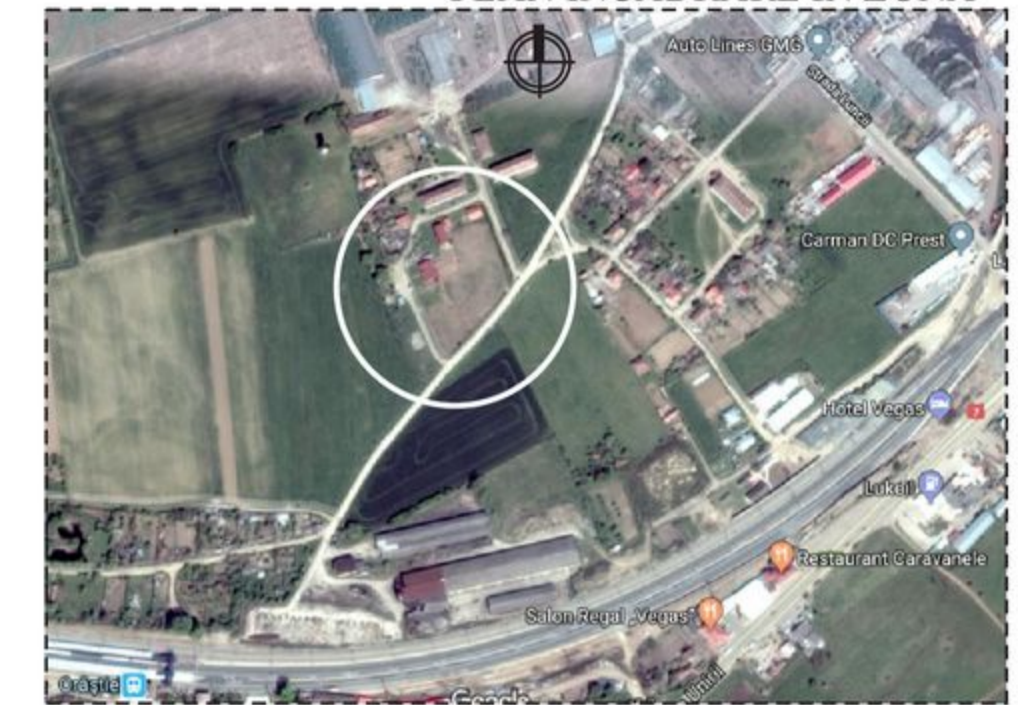

### LEGENDA

- Constructii existente
- Constructii propuse
- Drum modernizat
- Drum nemodernizat
- Zone verzi
- Stalp LEA
- Acces pe proprietatea beneficiarilor
- Accese in cladire
- Limita proprietate

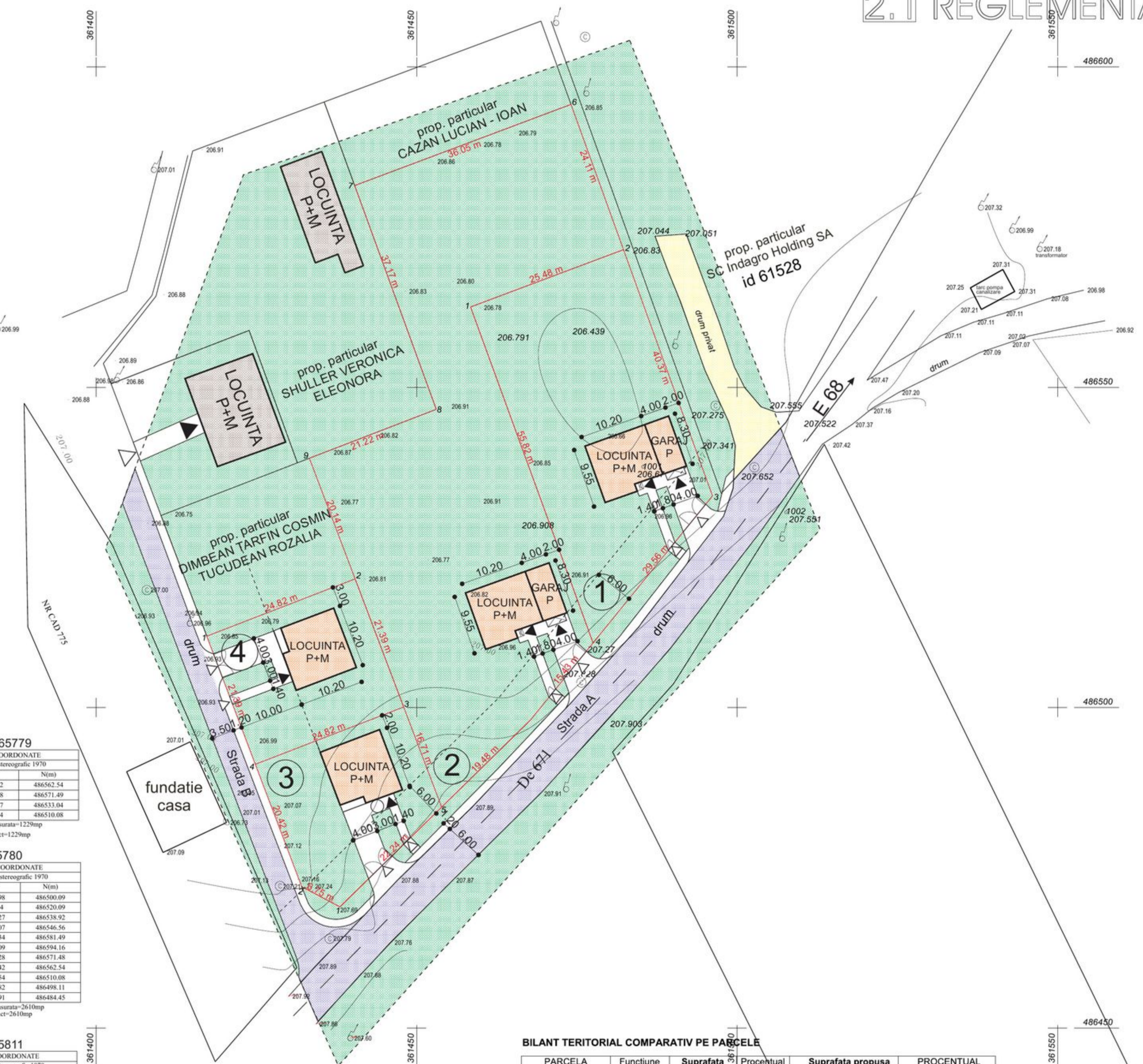

**1 id. 65779**  
INVENTAR DE COORDONATE  
Sistem de proiectie: stereografic 1970

Pct.	E(m)	N(m)
1	361458.42	486562.54
2	361482.28	486571.49
3	361496.17	486533.04
4	361477.54	486510.08

Suprafata totala masurata=1229mp  
Suprafata din act=1229mp

**2 id. 65780**  
INVENTAR DE COORDONATE  
Sistem de proiectie: stereografic 1970

Pct.	E(m)	N(m)
3	361447.98	486500.09
2	361440.4	486520.09
9	361433.27	486538.92
8	361453.07	486546.56
7	361440.34	486581.49
6	361474.09	486594.16
2	361482.28	486571.48
1	361458.42	486562.54
4	361477.54	486510.08
10	361467.82	486498.11
5	361453.91	486484.45

Suprafata totala masurata=2610mp  
Suprafata din act=2610mp

**3 id. 65811**  
INVENTAR DE COORDONATE  
Sistem de proiectie: stereografic 1970

Pct.	E(m)	N(m)
1	361438.04	486468.88
2	361432.07	486472.05
4	361424.83	486491.14
3	361447.98	486500.09
5	361453.91	486484.45

Suprafata totala masurata=532mp  
Suprafata din act=532mp

**4 id. 65725**  
INVENTAR DE COORDONATE  
Sistem de proiectie: stereografic 1970

Pct.	E(m)	N(m)
1	361417.25	486511.34
2	361440.4	486520.09
3	361447.98	486500.09
4	361424.83	486491.14

Suprafata totala masurata=531mp  
Suprafata din act=531mp

### BILANT TERITORIAL COMPARATIV GENERAL

S<sub>TEREN</sub> = 4902,00 mp

Funciune	Suprafata Existenta (m <sup>2</sup> )	Procentual %	Suprafata propusa S <sub>c</sub> (m <sup>2</sup> )	S <sub>cd</sub> (m <sup>2</sup> )	POT %	CUT
Constructii	0,00	0,00	480	600	9,79	0,12
Carosabil	0,00	0,00	144		2,94	
Pietonal	0,00	0,00	76		1,55	
Spatii plante	4902,00	100,00	4202		85,72	

### BILANT TERITORIAL COMPARATIV PE PARCELE

PARCELA	Funciune	Suprafata Existenta (m <sup>2</sup> )		Suprafata propusa		PROCENTUAL	
		Existenta (m <sup>2</sup> )	Procentual %	S <sub>c</sub> (m <sup>2</sup> )	S <sub>cd</sub> (m <sup>2</sup> )	POT %	CUT
PARCELA 1 S <sub>TEREN</sub> = 1229,00 mp	Constructii	0,00	0,00	130	190	10,58	0,15
	Carosabil	0,00	0,00	32		2,60	
	Pietonal	0,00	0,00	18		1,46	
	Spatii plante	1229,00	100,00	1049		85,35	
PARCELA 2 S <sub>TEREN</sub> = 2610,00 mp	Constructii	0,00	0,00	130	190	4,98	0,07
	Carosabil	0,00	0,00	32		1,23	
	Pietonal	0,00	0,00	18		0,69	
	Spatii plante	2610,00	100,00	2430		93,10	
PARCELA 3 S <sub>TEREN</sub> = 532,00 mp	Constructii	0,00	0,00	110	110	20,68	0,21
	Carosabil	0,00	0,00	40		7,52	
	Pietonal	0,00	0,00	20		3,76	
	Spatii plante	532,00	100,00	362		68,05	
PARCELA 4 S <sub>TEREN</sub> = 531,00 mp	Constructii	0,00	0,00	110	110	20,72	0,21
	Carosabil	0,00	0,00	40		7,53	
	Pietonal	0,00	0,00	20		3,77	
	Spatii plante	531,00	100,00	361		67,98	

- 1 Proprt.particular PREDESCU VASILE CLAUDIU BUDUR FELICIA C.F.nr.65779, nr.cad.65779, S<sub>teren</sub> = 1.229,00 m<sup>2</sup>
- 2 Proprt.particular DIMBEAN VERONICA C.F.nr.65812, nr.cad.65812, S<sub>teren</sub> = 2.610,00 m<sup>2</sup>

- 3 Proprt.particular UNGUREANU FLORIN MARIUS UNGUREANU ALEXANDRA IOANA C.F.nr.65811, nr.cad.65811, S<sub>teren</sub> = 532,00 m<sup>2</sup>
- 4 Proprt.particular UNGUREANU CIPRIAN UNGUREANU DORINA ANCA C.F.nr.65725, nr.cad.65725, S<sub>teren</sub> = 531,00 m<sup>2</sup>

<b>C&amp;M GeProTim srl Brad</b> J20/144/1999, RO 11546050	Beneficiar:	DIMBEAN VERONICA, PREDESCU VASILE, BUDUR FELICIA, UNGUREANU FLORIN, UNGUREANU CIPRIAN Mun.Orastie, jud. HD	PROIECT nr. 982
	Sef proiect Arh.CRING C. Proiectat Arh.CRING C. Desenat Ing.BENEA C.	SCARA: 1:500 DATA: Apr.2018	Titlu proiect: Constructie locuinte familiale P+M, garaje si imprejurire terenuri Mun.Orastie, str.Luncii, f.n. jud. HD Titlu plansa: PLAN DE SITUATIE REGLEMENTARI URBANISTICE - ZONIFICARE

Aceste desene si specificatii sunt proprietatea S.C. C&M GeProTim S.R.L. Brad. Nu vor fi copiate sau reproduse fara acordul scris al acesteia.